

Machine Accessories

CENTER AND FOLLOWER REST

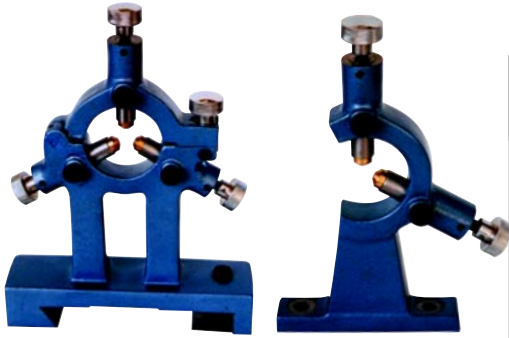

Center Rest Height	Follower Rest Height	Model No.
150mm	140mm	200-2540
230mm	187mm	200-2542
200mm	157mm	200-2544
180mm	137mm	200-2546
160mm	126mm	200-2548
170mm	144mm	200-2550
150mm	124mm	200-2552

STANDARD CHUCK KEYS

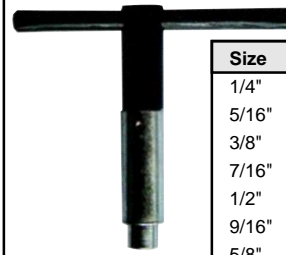

Size	Model No.
1/4"	290-1171
5/16"	290-1172
3/8"	290-1173
7/16"	290-1174
1/2"	290-1175
9/16"	290-1176
5/8"	290-1177
11/16"	290-1178
3/4"	290-1179

5C & R8 PRECISION CHUCKS

Scroll type, chucks come with attached 5c back plate, 2 set of solid jaws, chuck wrench.

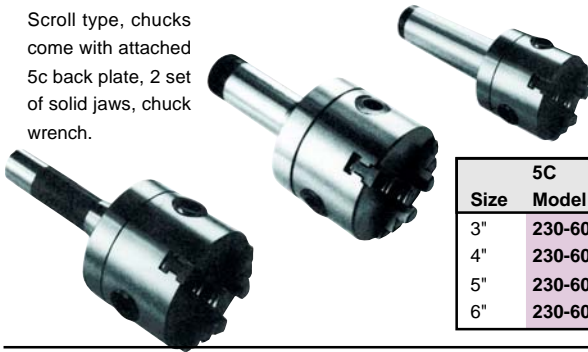

	5C	R8
Size	Model No.	Model No.
3"	230-6003	230-6013
4"	230-6004	230-6014
5"	230-6005	230-6015
6"	230-6006	230-6016

2-JAW SELF-CENTERING CHUCKS

Standard Accuracy, Semi-Steel Body, Soft two piece jaws, Shape to Fit work pieces.

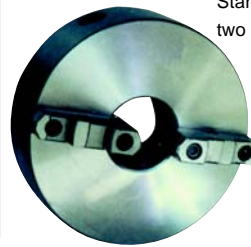

Chuck Dia.	Thru Radial Hole	Model No.
6"	0.0012 1.65	428-7106
8"	0.0016 2.16	428-7108
10"	0.0016 2.99	428-7110
12"	0.0020 4.05	428-7112

3 & 4- JAW PLAIN BACK SELF-CENTERING CHUCKS

Plain back, universal scroll chucks. for adaptor mounting. has 2 sets solid jaws & 2 piece jaws

3-Jaw



Chuck Dia.	Thru Hole	Model No.
3"	0.630"	429-3003
4"	0.866"	429-3004
5"	1.181"	429-3005
6"	1.575"	429-3006
8"	2.559"	429-3008
10"	3.150"	429-3010
12"	3.937"	429-3012
15"	4.000"	429-3015

4-Jaw



Chuck Dia.	Thru Hole	Model No.
5"	1.181"	428-8205
6"	1.575"	428-8206
8"	2.559"	428-8208
10"	3.150"	428-8210
12"	3.937"	428-8212
15"	4.000"	428-8215
20"	6.25"	428-8220

3 & 4 JAW DIRECT MOUNT D1 CAMLOCK CHUCKS

the advantage of using a direct mount chuck is extra working capacity on the lathe due to a shouter overall length with the integral camlock mount.

3-Jaw Universal



Chuck Dia.	Spindle	Thru Hole	Model No.
6"	D1-3	1.575"	429-3063
6"	D1-4	1.575"	429-3064
6"	D1-5	1.575"	429-3065
8"	D1-4	1.969"	429-3084
8"	D1-5	1.969"	429-3085
8"	D1-6	1.969"	429-3086
10"	D1-5	2.756"	429-3105
10"	D1-6	2.756"	429-3106
10"	D1-8	2.756"	429-3108
12"	D1-11	3.937"	429-3121
12"	D1-6	3.937"	429-3126
12"	D1-8	3.937"	429-3128
15"	D1-11	5.11"	429-3151
15"	D1-8	5.11"	429-3158
16"	D1-11	4.95"	429-3161

4-Jaw Independent



Chuck Dia.	Spindle	Thru Hole	Model No.
8"	D1-4	2.165"	429-4084
10"	D1-5	2.953"	429-4105
10"	D1-6	2.953"	429-4106
12"	D1-6	3.740"	429-4126
16"	D1-8	4.921"	429-4168

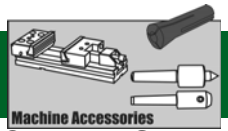

4- JAW INDEPENDENT FLAT BACK CHUCKS



The chuck body is made of cast iron. The reversible jaws and operation screw are made of high quality carbon steel jaws and are hardened precision ground.

Chuck Dia.	Hole Circle	Thru Hole	Model No.
3"	2.59	0.86"	429-4003
6"	5-23/32	1-1/2"	429-4006
8"	4-9/67	1-15/16"	429-4008
10"	4-3/4	2-1/21"	429-4010
12"	6-1/2	3-3/4"	429-4012
16"	8-15/16	3-1/2"	429-4016
20"	9-1/4	6-1/4"	429-4020

SELF-EJECTING CHUCK KEYS

- Hardened & tempered.
- Heavy duty construction.
- Made to fit all makes of chucks.

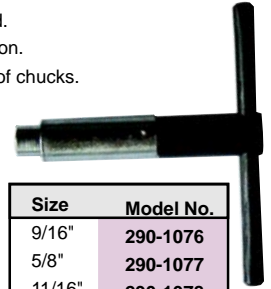

Size	Model No.
1/4"	290-1071
5/16"	290-1072
3/8"	290-1073
7/16"	290-1074
1/2"	290-1075

Size	Model No.
9/16"	290-1076
5/8"	290-1077
11/16"	290-1078
3/4"	290-1079

6- JAW FLAT BACK, SELF-CENTERING, UNIVERSAL SCROLL CHUCKS

These chucks are suitable for clamping and machining the thin-walled workpieces, especially the handle-cutting tools.

By using this series of chucks, the deformation can be reduced or avoided when the workpieces are gripped and the grinding states can be improved owing to their evenbearing

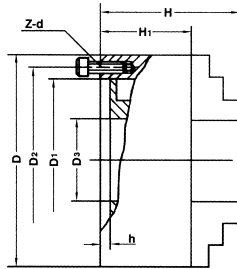
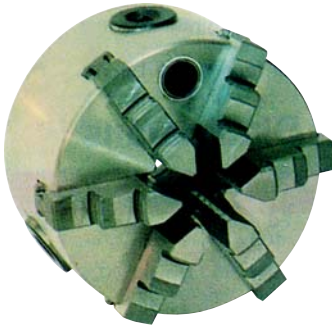

Dimensions	Model No. 429-6004	Model No. 429-6005	Model No. 429-6006	Model No. 429-6008
D	100mm(4")	130mm(5")	165mm(6")	200mm(8")
D1	72	100mm	130mm	165mm
D2	84	115mm	145mm	180mm
D3	26	35mm	42mm	65mm
H	73	86mm	96.5mm	109mm
H1	53.5	60mm	66.5mm	75mm
h	3.5	3.5mm	4.5mm	5mm
z-d	3-M8	3-M8	3-M8	3-M10

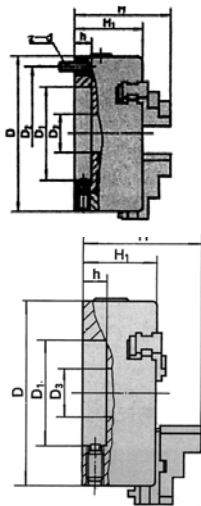

PRECISION ADJUSTABLE RUN-TRUE CHUCKS

This series chucks are made of high quality materials with precision machining, and the bodies enjoy nice rigidity. What is more, the chucks have a high repeatable concentric precision. With suitable adjustment the chuck's clamping precision can reach 0.013mm.

3-Jaw Adjustable Chucks

	Model No. 429-3165	Model No. 429-3600	Model No. 429-3200	Model No. 429-3825	Model No. 429-3250	Model No. 429-3910	Model No. 429-3325	Model No. 429-3912
Size	165mm	6"	200mm	8"	250mm	10"	325mm	12"
D	165	6.49"	204	8.03"	254	10"	330	12.99"
D1	80	3.15"	120	4.724"	150	5.90"	200	7.874"
D2	145	5.70"	180	7.08"	226	8.89"	296	11.653"
D3	40	1.575"	65	2.56"	80	3.15"	100	3.937"
H	102	4.01"	112	4.41"	138	5.433"	158.5	6.24"
H1	72	2.835"	78	3.07"	88	3.464"	100	3.937"
h	13.5	0.531"	13.5	0.531"	18	0.708"	20.5	0.807"
z-d	6-M8	6-1/4-18	6-M10	6-3/8-16	6-M12	6-7/16"-14	6-M16	6-1/2-13

6-Jaw Adjustable Chucks

	Model No. 429-6160	Model No. 429-6600	Model No. 429-6200	Model No. 429-6825	Model No. 429-6250	Model No. 429-6910	Model No. 429-6315	Model No. 429-6912
Size	160mm	6"	200mm	8"	250mm	10"	315mm	12"
D	152.5mm	6	210	8.27	254	10	305	12
D1	79.37	3.125	120.65	4.75	161.90	6.374	200.79	7.905
D2	135.70	5.343	190.5	7.5	111.13	4.375	133.35	5.25
D3	39	1.535	57.5	2.264	72	2.835	83	3.268
H	98.6	3.882	132.2	5.206	153.8	6.056	166.9	6.569
H1	59	2.323	79.3	3.122	88.7	3.492	101.1	3.980
h	17.5	0.689	19.1	0.752	20.4	0.803	20.4	0.803
z-d	6-M6	6-1/4-20	6-M10	6-3/8-16	6-M12	6-7/16-14	6-M12	6-1/2-13

